

UPPER SUPPORT POST

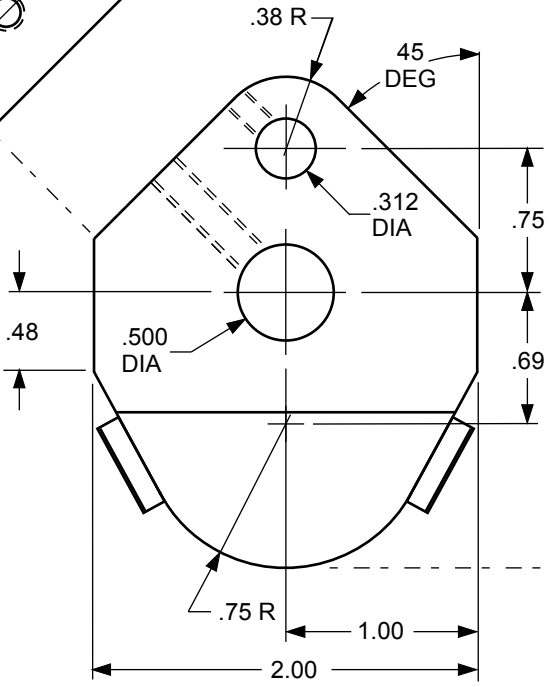

LOWER SUPPORT ASSEMBLY

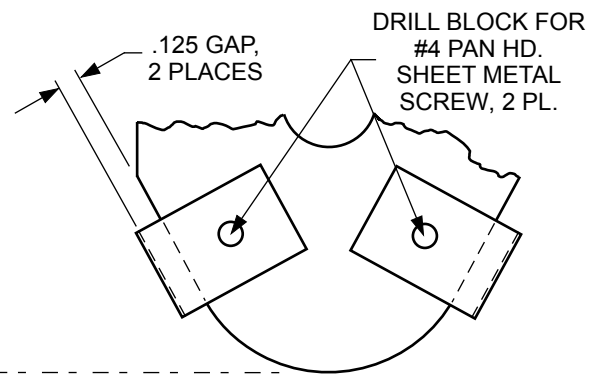
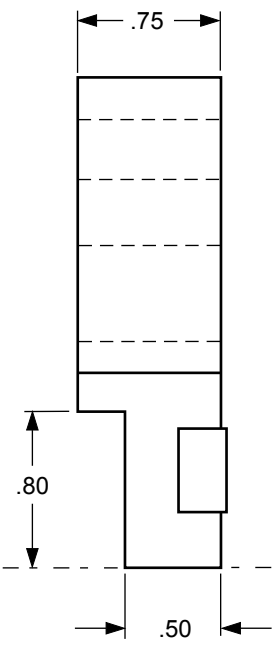

DRILL BLOCK FOR #4 PAN HD. SHEET METAL SCREW, 2 PL.

**NOTES:**

MAKE SUPPORT BLOCK FROM ANY HARD, MACHINABLE MATERIAL (ALUMINUM, PHENOLIC, CORIAN, ETC.)

UPPER AND LOWER CLIPS MADE FROM .015 THK X .50 WIDE STEEL PALLET BANDING.

UPPER SUPPORT POST MADE FROM .312 (5/16") DIA 6061-T6 ALUMINUM ROD

MAIN CENTER POST MADE FORM 6061-T6 ALUMINUM TUBE, .500 OD x .032 WALL

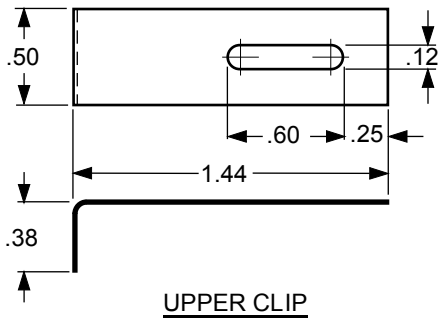

UPPER CLIP

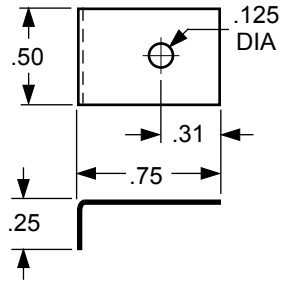

LOWER CLIP

	TITLE DISPLAY MOUNT, ECTO-GOGGLES - DETAIL VIEWS		
	SCALE 1:1	MEDIA SIZE 8.5 x 11	
	DRAWN BY "Busybuildr"		DATE 7 OCT 2008